

ANGLE SEAT VALVE

Model#
NS0150-N

SIZE 1 1/2"

BI DIRECTIONAL AIR ACTUATED ANGLE SEAT VALVE

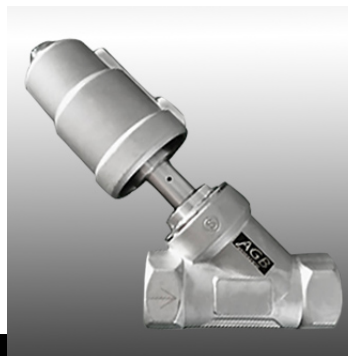

Technical Specifications

1 1/2"

Air Cylinder

- Material: 304, 304
- Rotation: 360°
- Max Working Pressure:
- Flow (Top) 232 psi, Flow (Bottom) 362 psi
- Minimum Required Pressure: 66psi
- Control Fluid : Neutral gas, Air

VALVE

- Valve Body Material: 304 or 316 SS
- Sizes 3/8" to 2"
- Self-locking upon power loss or air loss in system

VALVE INTERNAL

COMPONENTS FOR POLY ACTUATOR AND STAINLESS STEEL ACTUATOR

- System Features: suitable for steam and liquids in situations with a high requirement for water hammer prevention.
- Working Medium: 1. Ordinary type: suitable to $\leq 356^{\circ}\text{F}$ steam or gas; 2. High temperature type: suitable $\geq 356^{\circ}\text{F}$ and $\leq 482^{\circ}\text{F}$ steam or gas. It can be used for liquid under certain situations (pressure release discharge of liquid).
- Medium flow direction: medium flows to the top or bottom of valve seat.

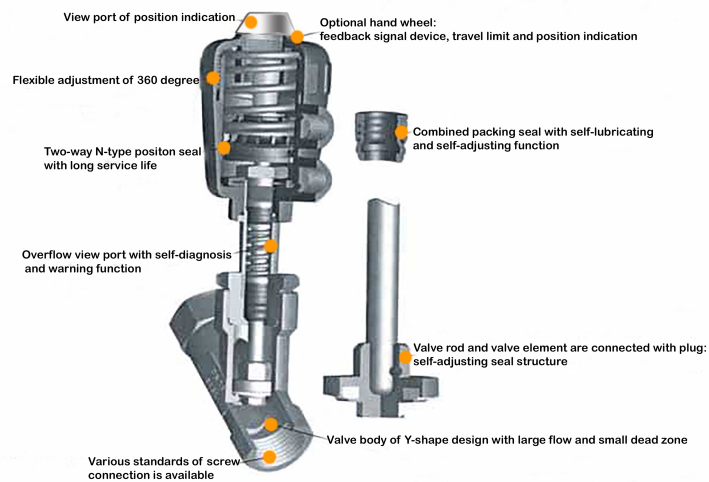

Air Placement Instructions:

Normally Closed

Air applied to port two of the actuator head releases spring tension allowing valve to open

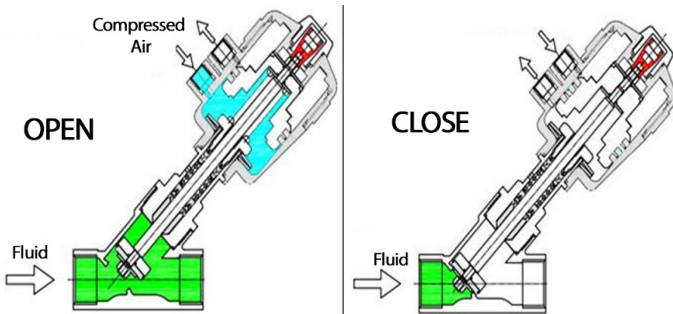

Normally Open

Air applied to port one of the actuator head compresses the spring allowing valve to close

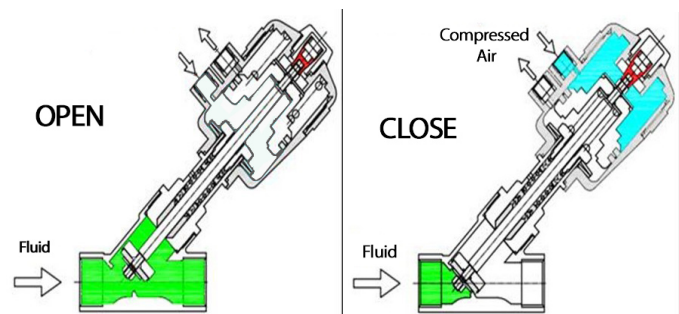

DIMENSIONS

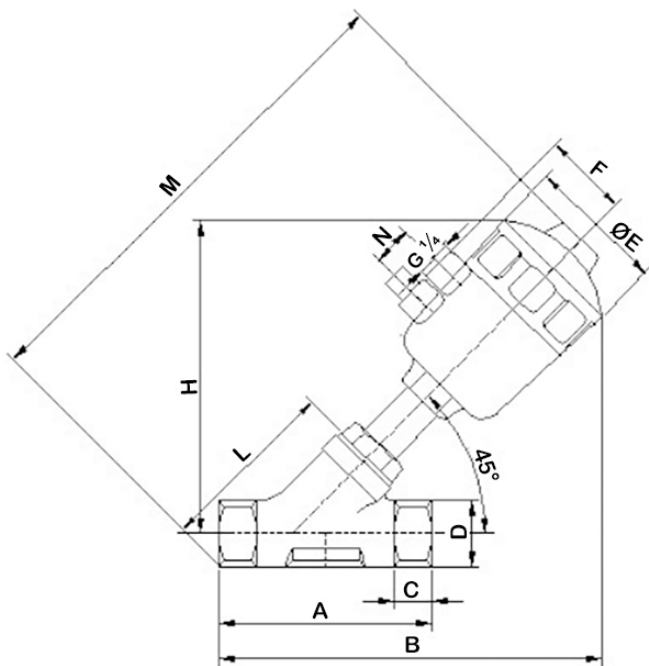

Easy to install
Infinitely rotatable actuator allows pneumatic connection in any position

Up to 3 million cycles

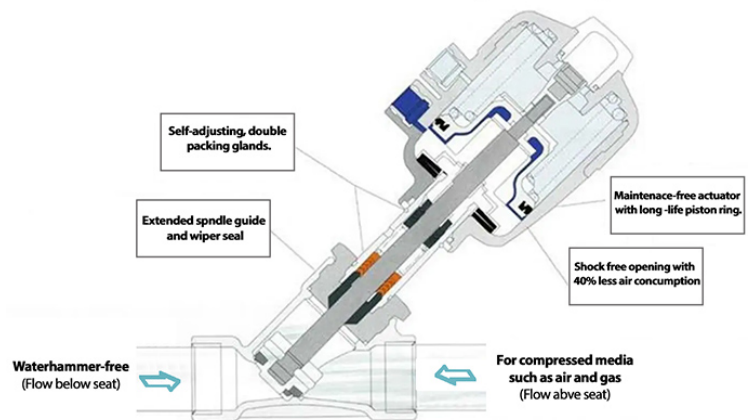

Size	Inner Bore	Actuator Standard	A	B	C	E	F	H	L	M	N	A/F	CV
1"1/2	1"37/64	2" 31/64	5" 1/8	9" 1/4	25/32"	3" 5/32	2" 1/8	7" 51/64	5" 1/8	12" 1/8	15/16"	2"11/64	49.1